

Model 10 Series



precision pneumatic & motion control

Pneumatic Precision Regulator



Flow Characteristics
Fairchild Model 10262

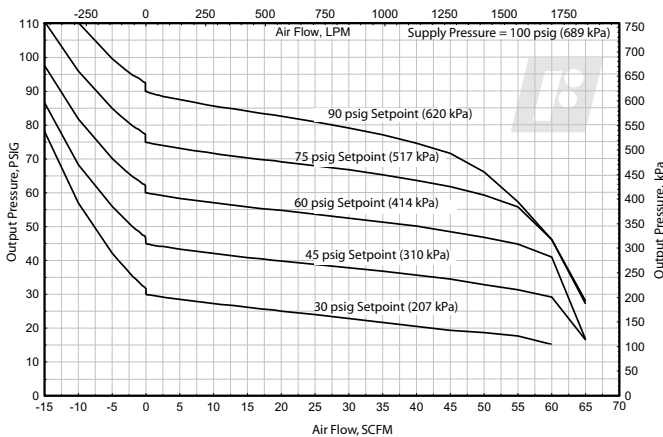

General Information

- Control sensitivity of 1/8" water column allows use in precision processes.
- Pressure balanced supply valve prevents supply pressure changes from affecting the setpoint.
- Optional check valve permits dumping of downstream pressure when supply is opened to atmosphere.
- Separate control chamber isolates the diaphragm from the main flow to eliminate hunting and buzzing.
- An aspirator tube compensates downstream pressure droop under flow conditions.
- Canadian Registration Number (CRN) certification for all territories and provinces.

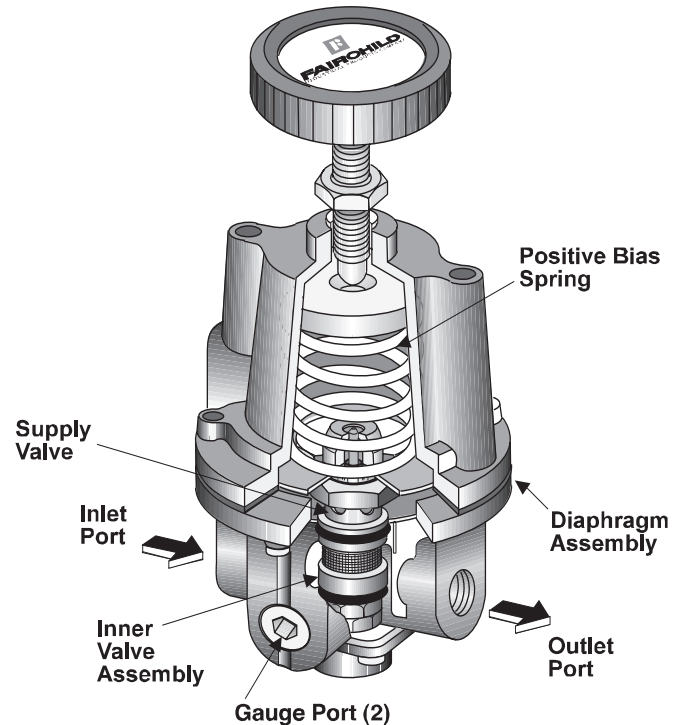

Cross Section

Model 10 Series Regulator Detail Drawing

Operating Principles

The Model 10 Series regulator use the force balance principal to control the movement of the Valve Assembly that controls the output pressure. When the regulator is adjusted for a specific set point, the downward force of the Positive Bias Spring moves the Diaphragm Assembly downward. The Supply Valve opens and allows air to pass to the Outlet Port. As the set point is reached, the downward force exerted by the Positive Bias Spring is balanced by the force of the downstream pressure that acts on the Diaphragm Assembly. The resultant force moves the Supply Valve upward to reduce the flow of air to the Outlet Port.

Outlet pressure is maintained as a result of balance between forces acting on the top and bottom of the Diaphragm Assembly. For more information, see cross sectional diagram.

Outline Dimensions

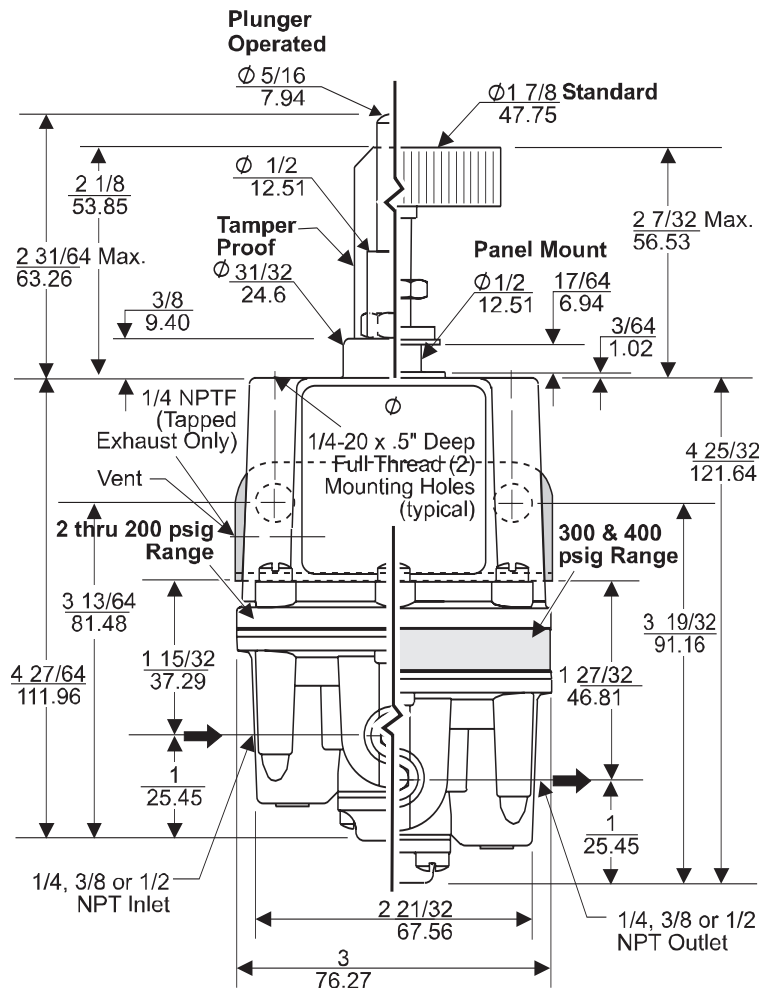

Specifications

Supply Pressure	500 psig, [35.0 BAR], (3500 kPa) Maximum
Flow Capacity	40 SCFM (68m ³ /HR) @ 100 psig, [7.0 BAR], (700 kPa) supply and 20 psig, [1.5 BAR], (150 kPa) setpoint
Exhaust Capacity	5.5 SCFM (9.35 m ³ /HR) where downstream pressure is 5 psig, [.35 BAR], (35 kPa) above 20 psig, [1.5 BAR], (150 kPa) setpoint
Supply Pressure Effect	Less than 0.1 psig, [.007 BAR], (.7 kPa) for 100 psig, [7.0 BAR], (700 kPa) change in supply pressure
Sensitivity	Less than 1/8" (.32 cm) water column
Ambient Temperature	-40°F to +200°F, (-40°C to 93.3°C)
Materials of Construction	Body and Housing Aluminum Diaphragms Buna N on Dacron (Standard Unit Only) Trim Brass, Zinc Plated Steel

Mounting Bracket

Part # 09921 - Zinc plated steel (sold separately)

Part # 14523 - 316 Stainless steel (sold separately)

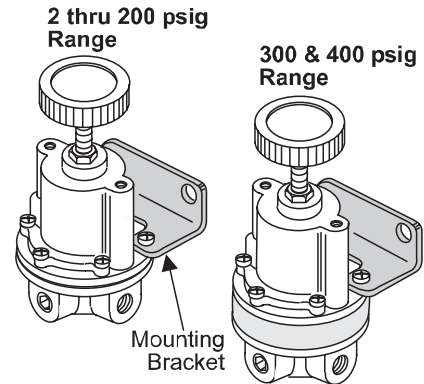
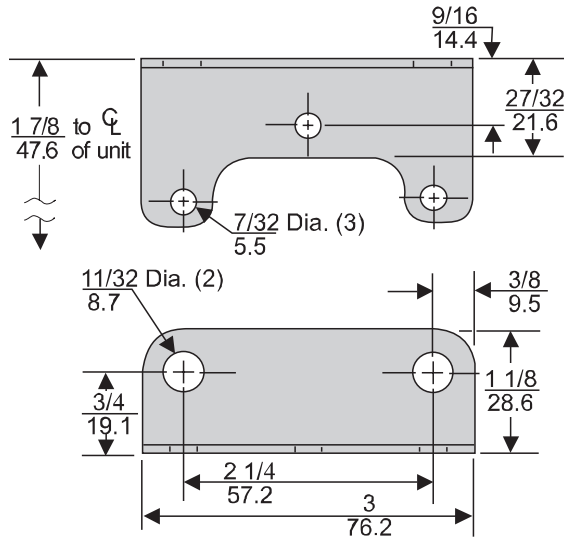

Option Information

Low Bleed (B)

Option that reduces the bleed rate below that of a standard unit and can be used when bleed or consumption is an issue. A reduction in sensitivity will result from the lower bleed rate.

Low Flow (L)

Option that increases the bleed rate above that of a standard unit to improve response in low flow applications.

Check Valve (C)

Internal check valve that permits rapid dumping of downstream pressure through the supply line and exhaust port when supply pressure is removed.

Non-Relieving (N)

Option that includes no relief function or continuous bleed. Units with this feature must operate with a continuous downstream flow to regulate properly and prevent the output from equalizing with supply line pressure.

Typical Application

A Model 10 regulator controls the air pressure in a tire molding process. During the process, low pressure is applied initially to the mold. As the process approaches the final stage, higher pressure is applied.

An automatic timer activates the solenoid valve and delivers low pressure to the mold. At a preset point in the cycle, an automatic timer transfers to the high pressure output of the solenoid valve and turns off the low pressure output.

At the end of the cycle, the high pressure to the mold is turned off and the mold exhausts into the atmosphere. When the mold closes, the cycle repeats. Interlock switches prevent the mold from opening under high pressure.

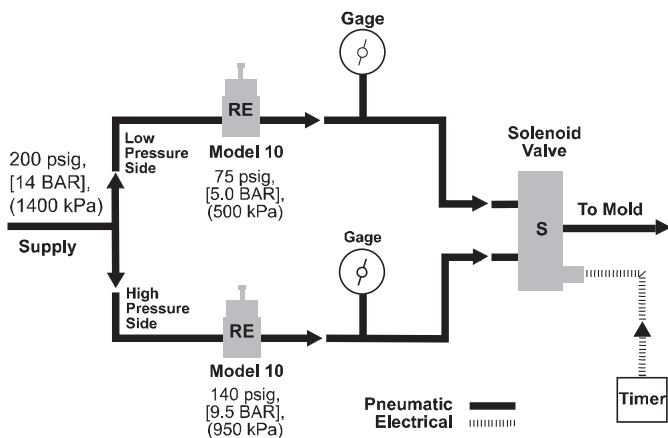

Installation

For installation instructions, see the *Fairchild Model 10 Pneumatic Precision Regulator Installation, Operation and Maintenance Instructions*, IS-1000010.



Fairchild Industrial Products Company
3920 West Point Boulevard • Winston-Salem, NC 27103
phone: 336-659-3400 • fax: 336-659-9323
sales@fairchildproducts.com • www.fairchildproducts.com

Catalog Information

Catalog Number 102

Pressure Range

psig	[BAR]	(kPa)	
0-2	[0-0.1]	(0-15)	1
0-10	[0-0.7]	(0-70)	2
0-20	[0-1.5]	(0-150)	0
.5-30	[0.03-2]	(3-200)	3
1-60	[0.1-4]	(10-400)	4
2-150	[0.1-10]	(15-1000)	6
3-200	[0.2-14]	(20-1400)	7
5-300	[0.3-21]	(35-2100)	8
5-400	[0.3-28]	(35-2800)	9

Pipe Size

1/4" NPT	2
3/8" NPT	3
1/2" NPT	4

Options

Silicone Elastomers¹

Low Bleed

Check Valve²

Tapped Exhaust

BSPP (Parallel)³

Fluorocarbon Elastomers

Low Flow

Non-Relieving

Panel Mount⁴

Plunger Operated⁵

Tamper Proof

BSPT (Tapered)

	A	B	C	E	H	J	L	N	P	R	T	U
A	-	Y	Y	Y	Y	N	Y	Y	Y	Y	Y	Y
B	Y	-	Y	Y	Y	N	N	Y	Y	Y	Y	Y
C	Y	Y	-	Y	Y	Y	N	Y	Y	Y	Y	Y
E	Y	Y	Y	-	Y	Y	Y	Y	N	Y	Y	Y
H	Y	Y	Y	Y	-	Y	Y	Y	Y	Y	N	Y
J	N	Y	Y	Y	Y	-	Y	Y	Y	Y	Y	Y
L	Y	N	Y	Y	Y	Y	-	N	Y	Y	Y	Y
N	Y	N	N	Y	Y	Y	N	-	Y	Y	Y	Y
P	Y	Y	Y	Y	Y	Y	Y	Y	-	N	N	Y
R	Y	Y	Y	N	Y	Y	Y	Y	N	-	N	Y
T	Y	Y	Y	Y	Y	Y	Y	Y	N	N	-	Y
U	Y	Y	Y	Y	N	Y	Y	Y	Y	Y	Y	-

¹ Maximum Supply Pressure - 75 psig, [5.0 BAR], (500 kPa)

² Maximum Supply Pressure - 250 psig, [17.200 BAR], (1700 kPa)

³ BSPP Threads in Inlet & Outlet Ports Only. Others BSPT.

⁴ Panel Mount available for ranges 1, 2, 0, 3, 4 and 6 only.

⁵ See Table 1 for Push Rod Travel and Thrust.

Table 1. Plunger Operated Regulator Parameters

Range	Push Rod Travel (inches)	Push Rod Thrust (pounds)
0-2 psig	.560 ± 10%	6.28 ± 10%
0-10 psig	.668 ± 10%	31.4 ± 10%
0-20 psig	.668 ± 10%	62.8 ± 10%
.5-30 psig	.673 ± 10%	94.2 ± 10%
1-60 psig	.698 ± 10%	188.4 ± 10%
2-150 psig	.589 ± 10%	471.0 ± 10%
5-300 psig	.589 ± 10%	471.0 ± 10%
3-200 psig	.418 ± 10%	628.0 ± 10
5-400 psig	.418 ± 10%	628.0 ± 10



precision pneumatic & motion control

CS-10000010
Rev. AB 01/06
Litho in USA